



LEICA TRI-ELMAR-M 16-18-21 mm f/4 ASPH.



With its impressive angle of view of 107°, this new TRI-ELMAR conquers 16 mm super wide-angle photography in perfect Leica M style. Due to the minimal distortion and barely perceptible field curvature, it can be recommended for highly demanding architecture photography even at the 16 mm setting. Used on the digital M8, it produces the image effect of a 21 - 28 mm lens, still enabling extreme wide-angle views. The ultra compact shape is achieved by two aspherical elements. A new design of the interior focusing significantly enhances the quality in the close-focus range through an adaption of the floating element principle. Brilliant depth of field can therefore be used from a distance of 0.33 m for hyperfocal photography. Save money by buying the lens in a set together with the Universal Wide-angle Viewfinder M.

— Lens shape 16 mm

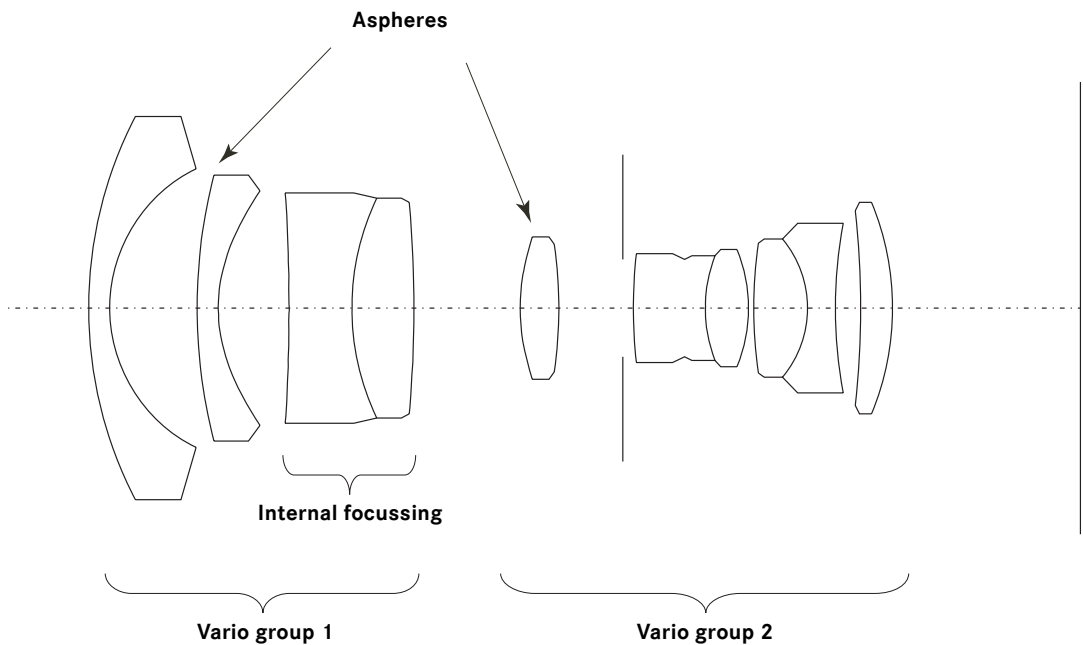



— Lens shape 18 mm

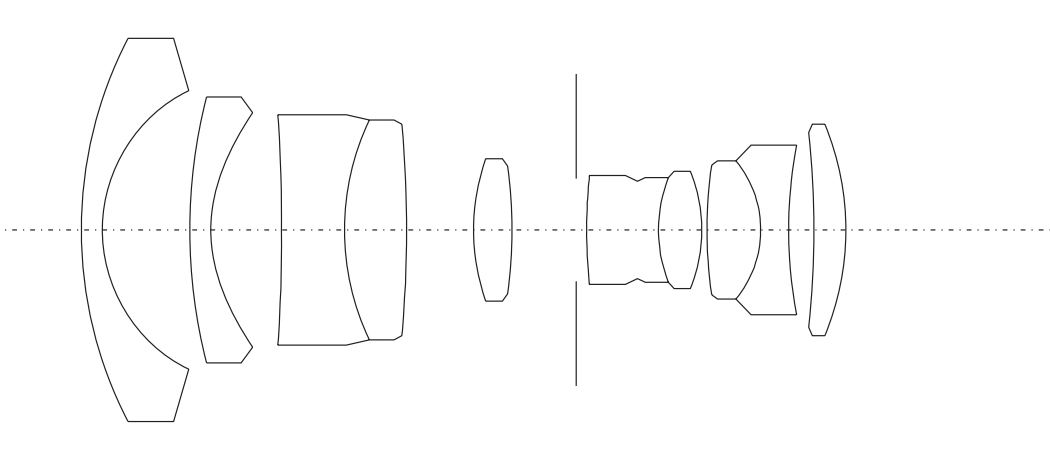

— Lens shape 21 mm

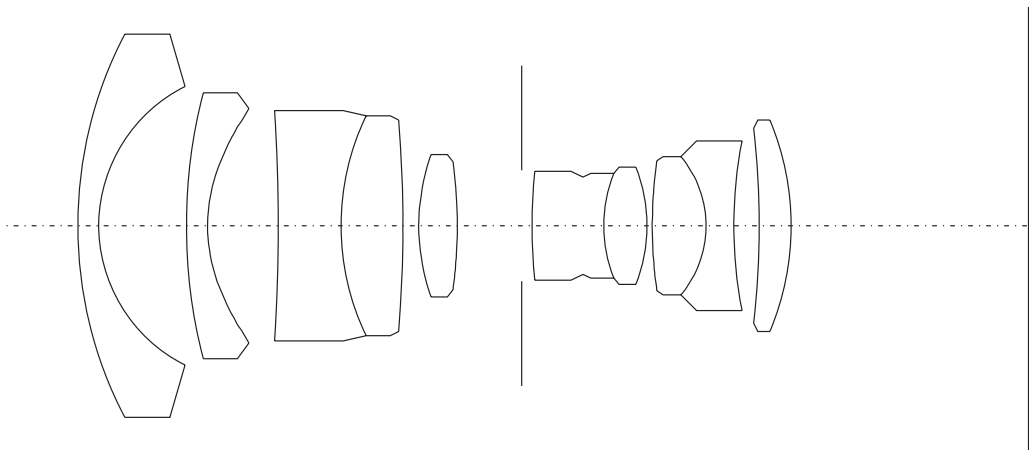



— Engineering drawing

Technical Data

Angle of view (diagonal, horizontal, vertical)	<p>for 35 mm (24 x 36 mm): at 16 mm: 107°, 97°, 74° at 18 mm: 100°, 90°, 67° at 21 mm: 92°, 81°, 60°</p> <p>for digital (18 x 27 mm): at 16 mm: 90°, 80°, 59° at 18 mm: 84°, 74°, 53° at 21 mm: 75°, 65°, 46°, corresponds approx. to a focal length of 21/24/28 mm with 35 mm-format</p>
Optical design	Number of elements / groups: 10 / 7
Distance setting	<p>Focusing range: 0.5 m to Infinity, range from 0.5 to 0.7 m separated by index</p> <p>Scales: Combined meter/feet graduation with uniform grey figures below 0.7 m</p> <p>Smallest object field:</p> <p>for 35 mm: at 16 mm: 915 x 1373 mm, approx. 1:38 at 18 mm: 833 x 1250 mm, approx. 1:35 at 21 mm: 725 x 1087 mm, approx. 1:30</p> <p>for digital: at 16 mm: 688 x 1032 mm, approx. 1:38 at 18 mm: 626 x 939 mm, approx. 1:35 at 21 mm: 545 x 817 mm, approx. 1:30</p> <p>Highest reproduction ratio: at 0,7 m at 16 mm: 1:38 at 18 mm: 1:35 at 21 mm: 1:30</p>
Aperture	<p>Setting / Function: Preset, with click-stops, half values available</p> <p>Lowest value: 22</p>
Bayonet	Leica M quick-change bayonet with 6 bit lens identification bar code for digital M models
Filter (type)	Male thread, non-rotating and with stop for filter holder or lens hood
Lens hood	screw-on type lens hood (included in delivery), filter holder for E67 size filters optionally available
Dimensions and weight	<p>Length: approx. 62/72 mm (with/without lens hood)</p> <p>Largest diameter: approx. 54 mm (53 x 58 mm with lens hood)</p> <p>Weight: approx. 335 g</p>



— MTF graphs 16 mm

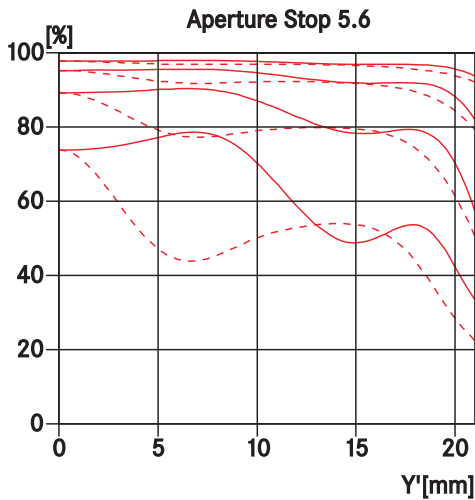
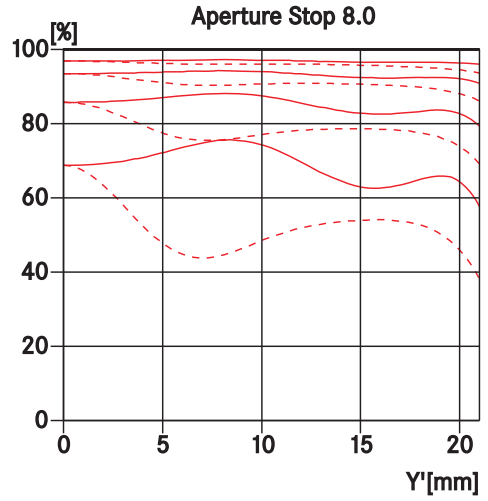
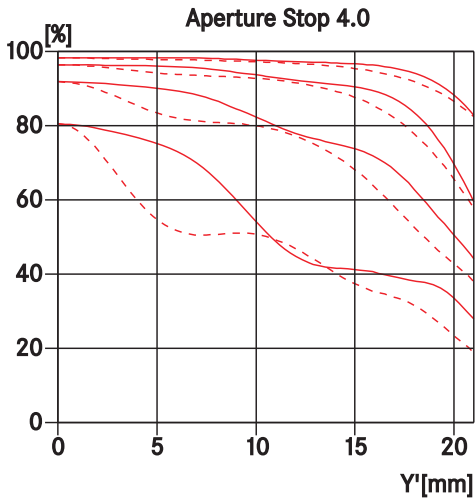

The MTF is indicated at full aperture and at f/5.6 and f/8.0 at long taking distances (infinity). Shown is the contrast in percentage for 5, 10, 20 and 40 lp/mm across the height of the 35 mm film format, for tangential (dotted line) and sagittal (solid line) structures, in white light. The 5 and 10 lp/mm will give an indication regarding the contrast ratio for large object structures. The 20 and 40 lp/mm records the resolution of finer and finest object structures.

- sagittal structures
- - - tangential structures

— Distortion 16 mm

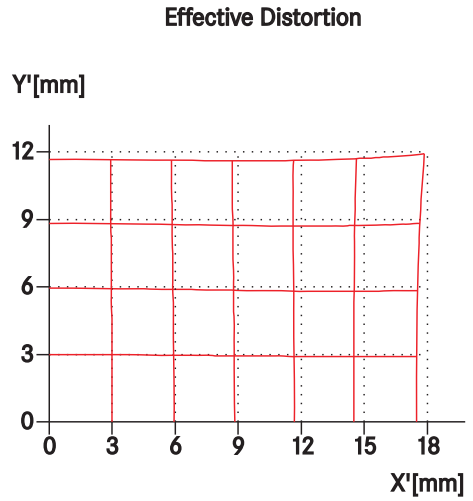
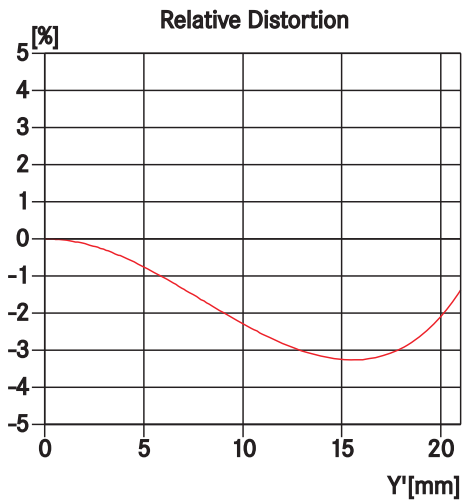

— Vignetting 16 mm

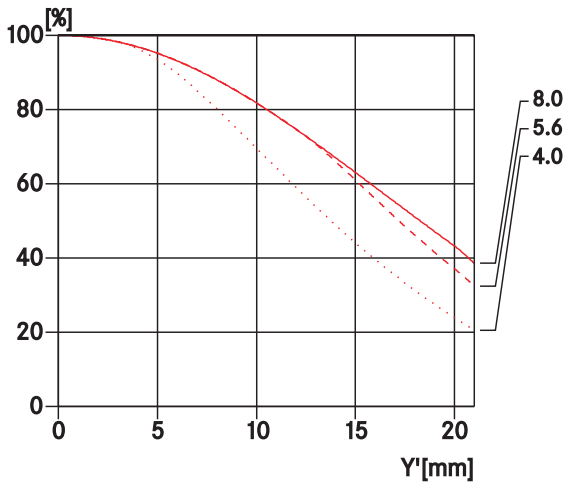

Distortion is the deviation of the real image height (in the picture) from the ideal image height. The relative distortion is the percentage deviation. The ideal image height results from the object height and the magnification. The image height of 21.6mm is the radial distance between the edge and the middle of the image field for the format 24mm x 36mm. The graph of the effective distortion illustrates the appearance of straight horizontal and vertical lines in the picture.

Vignetting is a continuous decrease of the illumination to the edges of the image field. The graph shows the percentage loss of illumination over the image height. 100% means no vignetting.



— 18 mm

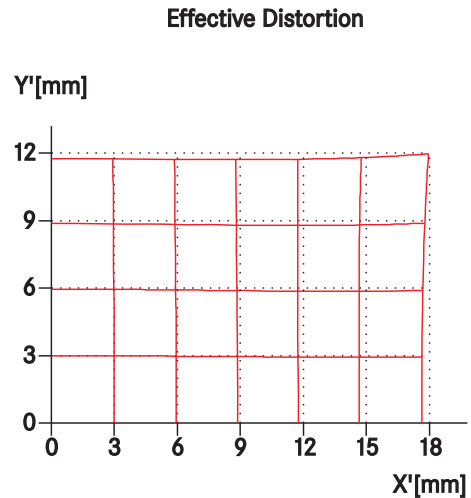
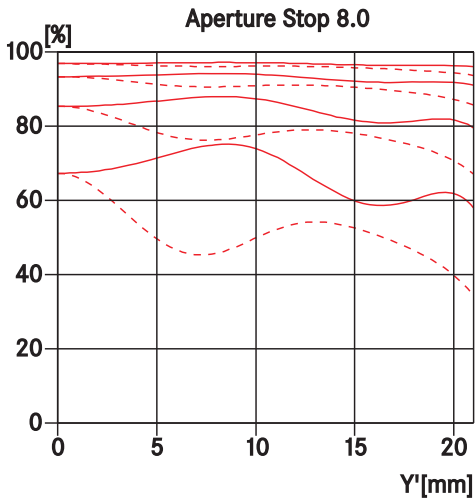
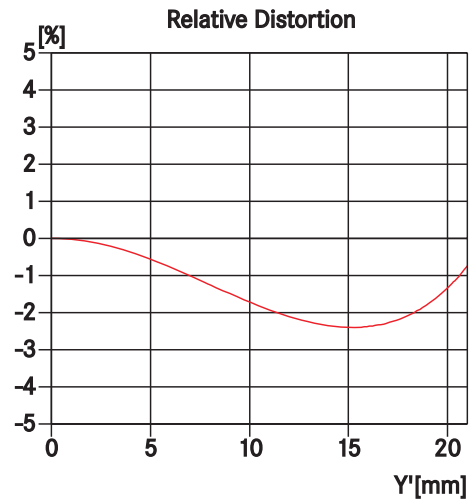
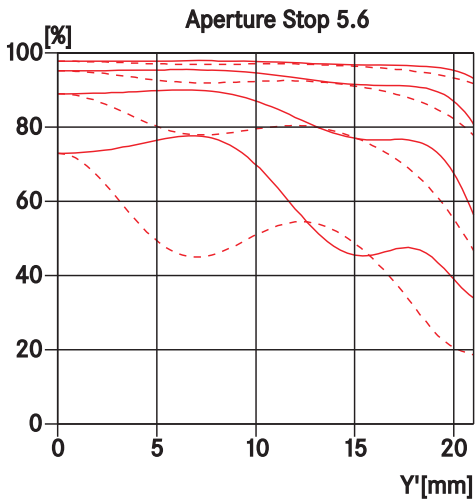
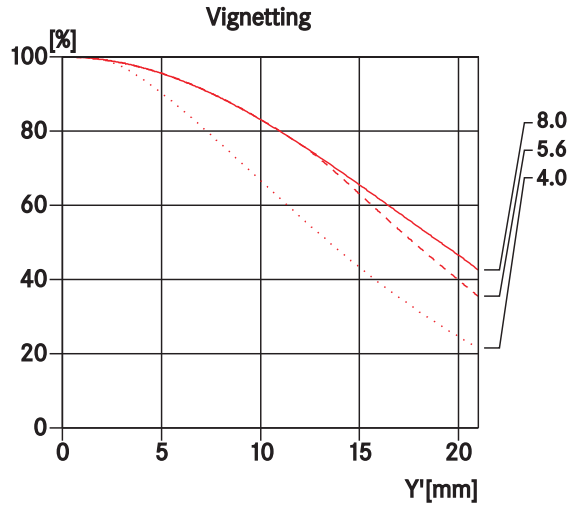
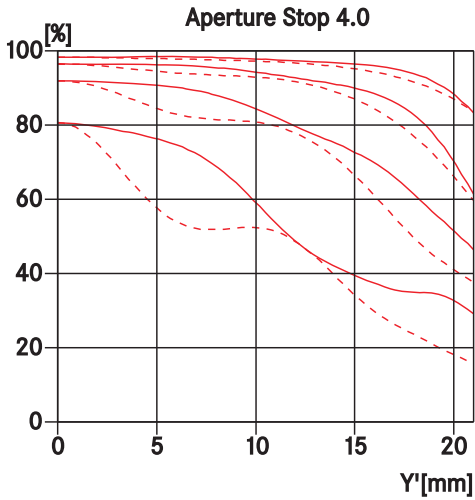



— 21 mm

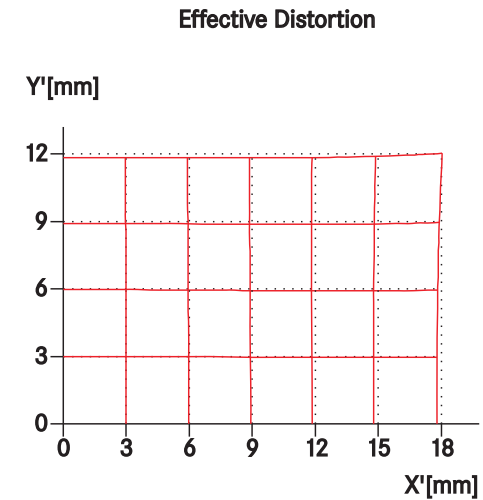
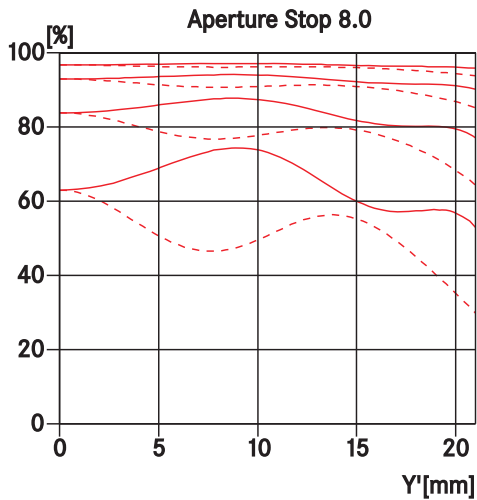
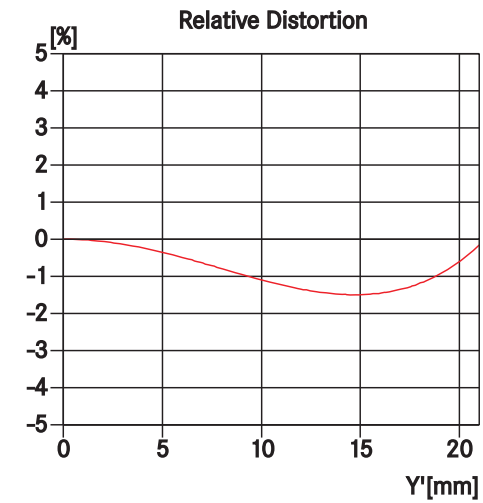
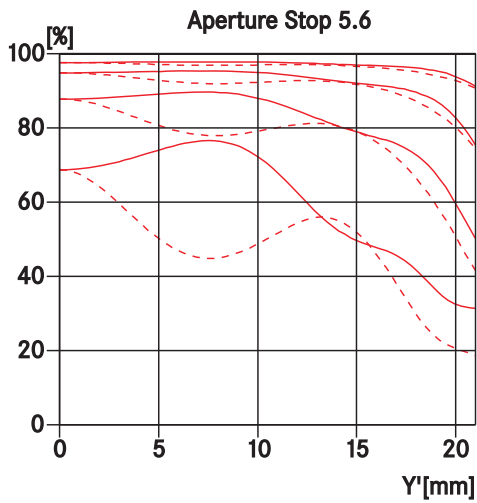
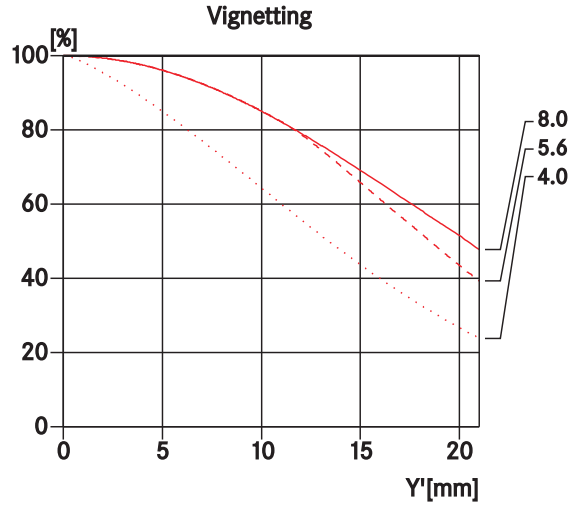
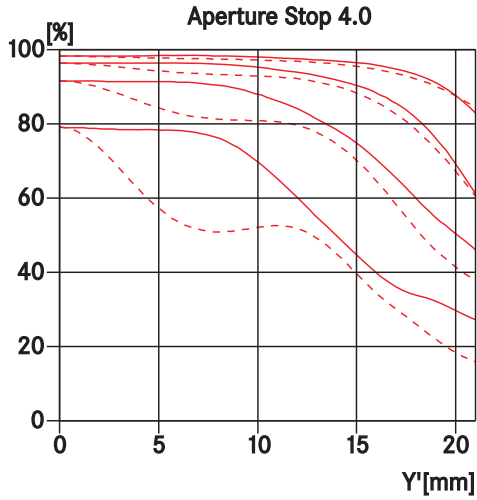



Depth of field table 16 mm

	Aperture Stop						Magnification
	4,0	5,6	8	11	16	22	
0,5	0,426 - 0,614	0,403 - 0,679	0,374 - 0,813	0,344 - 1,098	0,306 - 2,956	0,272 - ∞	1/25,9
0,6	0,491 - 0,786	0,460 - 0,904	0,420 - 1,178	0,381 - 1,963	0,333 - ∞	0,292 - ∞	1/32,
0,7	0,552 - 0,982	0,511 - 1,183	0,461 - 1,737	0,413 - 4,516	0,355 - ∞	0,307 - ∞	1/38,1
0,8	0,608 - 1,209	0,557 - 1,542	0,497 - 2,698	0,440 - 210,2	0,373 - ∞	0,319 - ∞	1/44,3
1	0,709 - 1,789	0,638 - 2,682	0,558 - 12,08	0,484 - ∞	0,402 - ∞	0,339 - ∞	1/56,6
1,5	0,910 - 4,969	0,792 - 214,2	0,666 - ∞	0,560 - ∞	0,449 - ∞	0,368 - ∞	1/87,2
2	1,060 - 45,22	0,899 - ∞	0,737 - ∞	0,607 - ∞	0,476 - ∞	0,385 - ∞	1/118
3	1,269 - ∞	1,041 - ∞	0,826 - ∞	0,663 - ∞	0,507 - ∞	0,403 - ∞	1/179
5	1,507 - ∞	1,190 - ∞	0,913 - ∞	0,715 - ∞	0,534 - ∞	0,418 - ∞	1/302
∞	2,093 - ∞	1,517 - ∞	1,085 - ∞	0,810 - ∞	0,582 - ∞	0,444 - ∞	1/∞

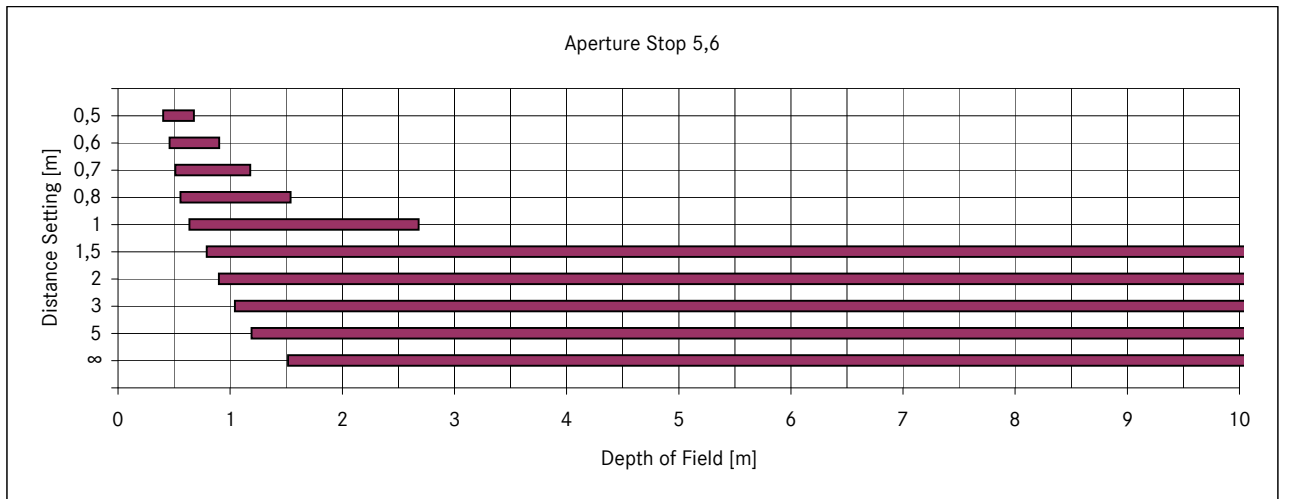
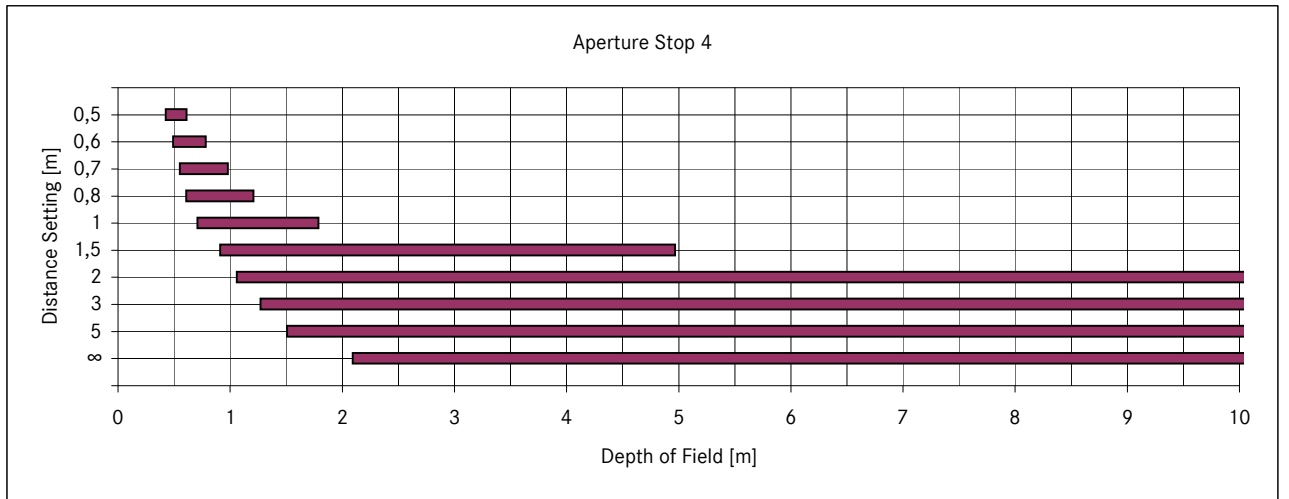



Aperture Stop 8

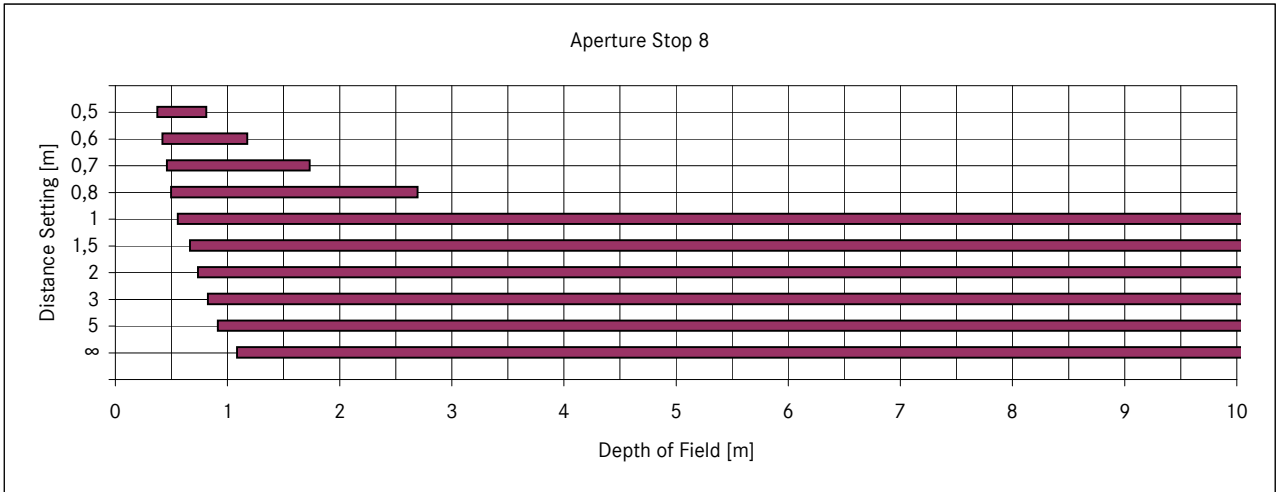

Aperture Stop 11

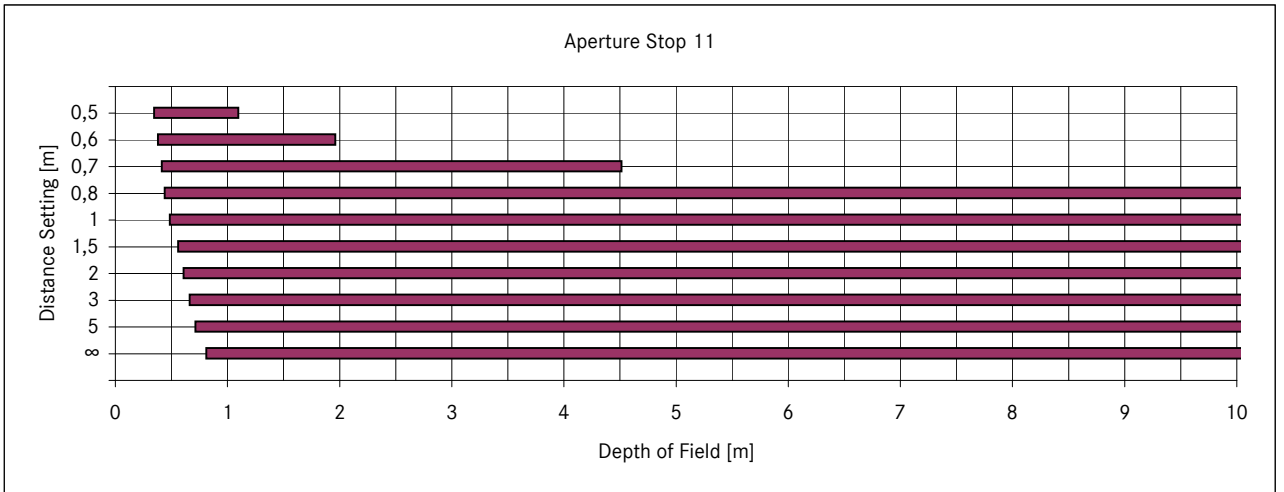

Aperture Stop 16

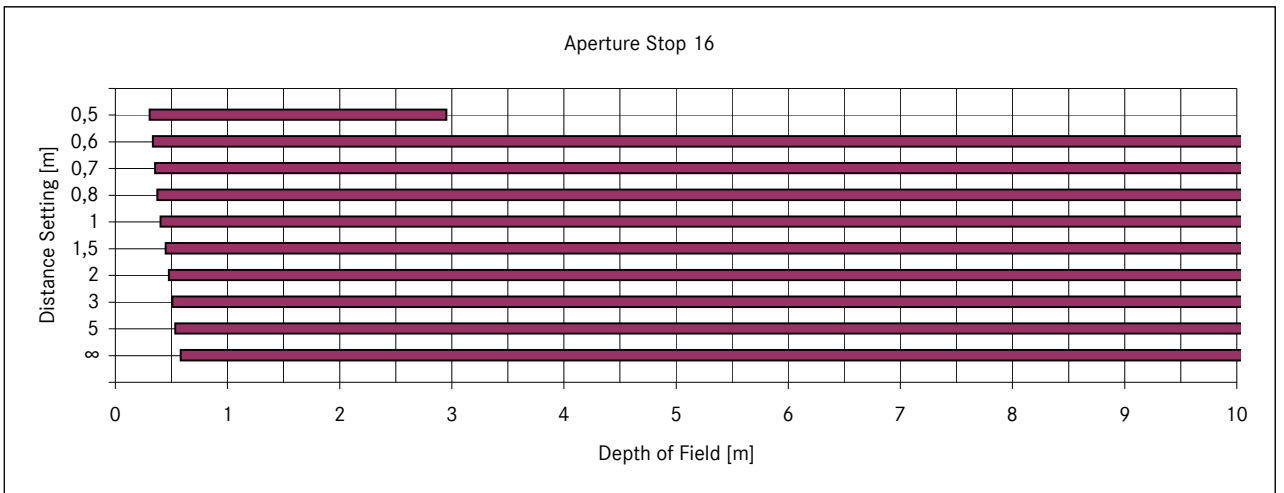

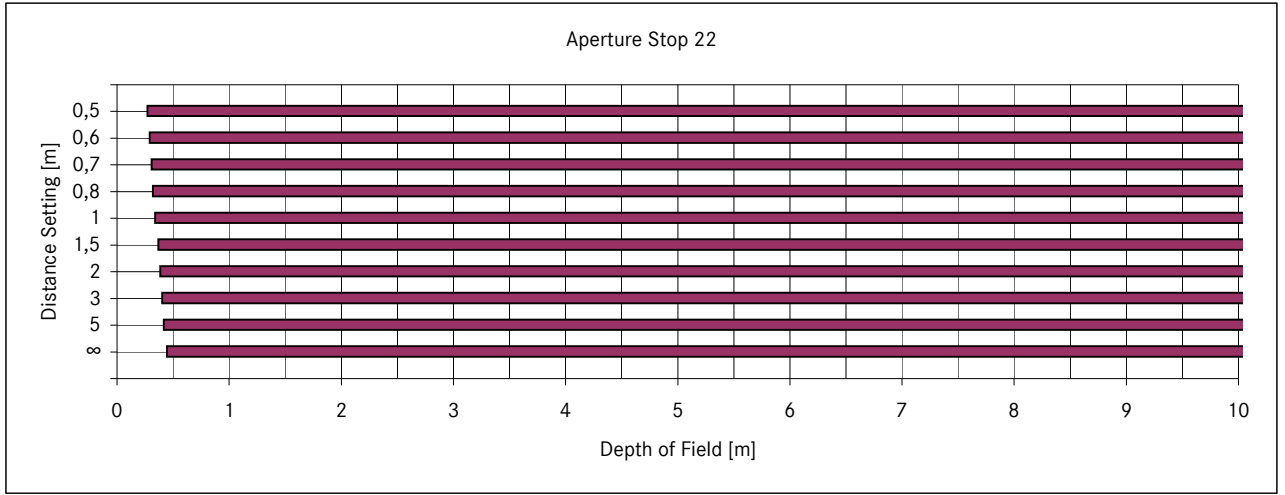



Depth of field table 18 mm

Distance Setting [m]	Aperture Stop						Magnification
	4,0	5,6	8	11	16	22	
0,5	0,436 - 0,591	0,416 - 0,639	0,389 - 0,732	0,361 - 0,901	0,325 - 1,527	0,291 - 16,32	1/23,6
0,6	0,506 - 0,746	0,478 - 0,829	0,441 - 1,004	0,404 - 1,383	0,356 - 4,164	0,315 - ∞	1/29,1
0,7	0,572 - 0,917	0,534 - 1,054	0,487 - 1,369	0,441 - 2,240	0,383 - ∞	0,334 - ∞	1/34,7
0,8	0,633 - 1,109	0,586 - 1,322	0,529 - 1,882	0,473 - 4,197	0,406 - ∞	0,350 - ∞	1/40,3
1	0,745 - 1,569	0,679 - 2,058	0,600 - 3,975	0,527 - ∞	0,442 - ∞	0,375 - ∞	1/51,4
1,5	0,974 - 3,513	0,859 - 7,995	0,732 - ∞	0,622 - ∞	0,502 - ∞	0,414 - ∞	1/79,3
2	1,151 - 9,245	0,990 - ∞	0,822 - ∞	0,683 - ∞	0,539 - ∞	0,436 - ∞	1/107
3	1,406 - ∞	1,168 - ∞	0,937 - ∞	0,757 - ∞	0,581 - ∞	0,461 - ∞	1/163
5	1,709 - ∞	1,364 - ∞	1,055 - ∞	0,828 - ∞	0,619 - ∞	0,483 - ∞	1/274
∞	2,523 - ∞	1,824 - ∞	1,299 - ∞	0,965 - ∞	0,688 - ∞	0,521 - ∞	1/∞

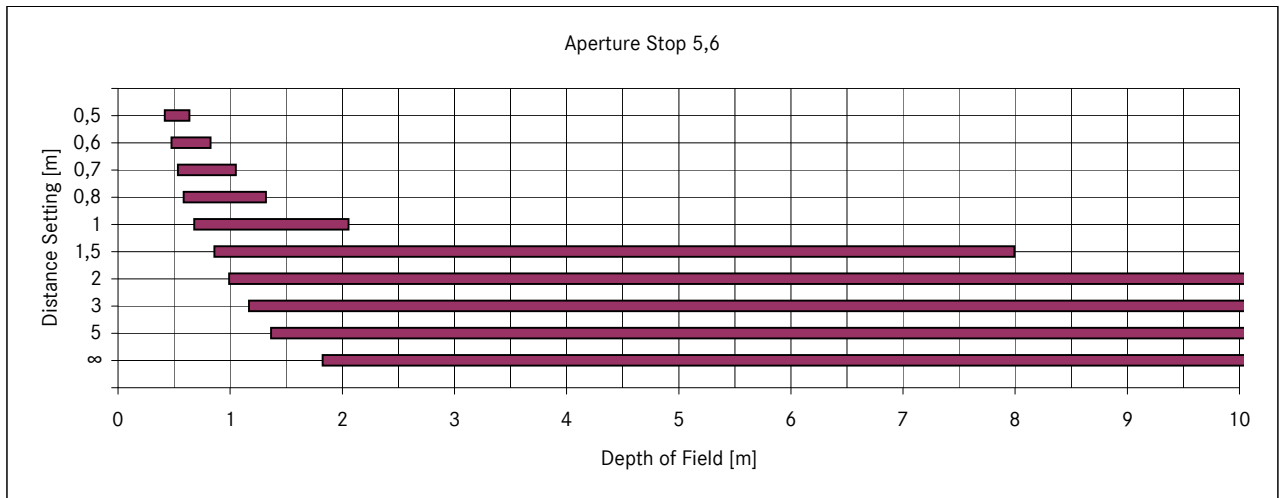
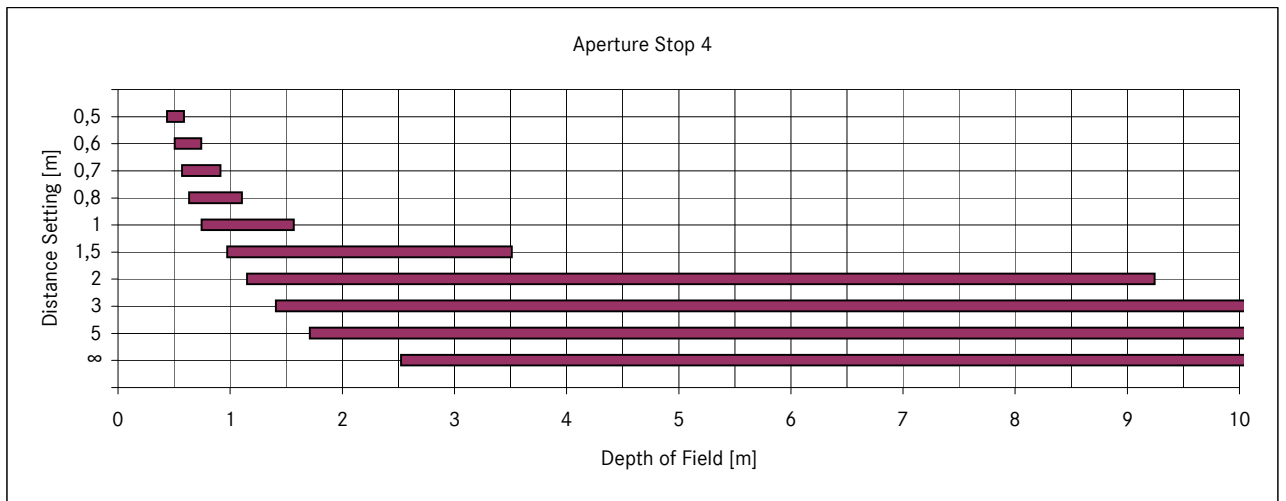



Aperture Stop 8

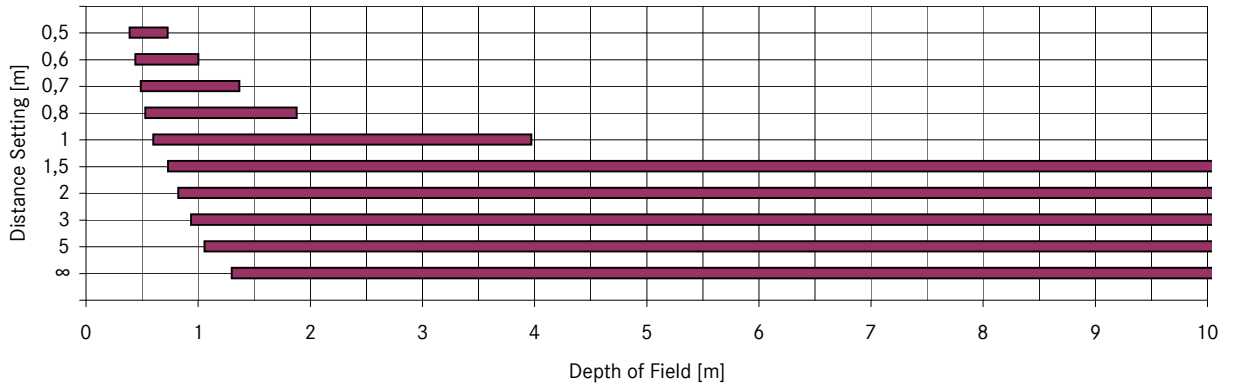

Aperture Stop 11

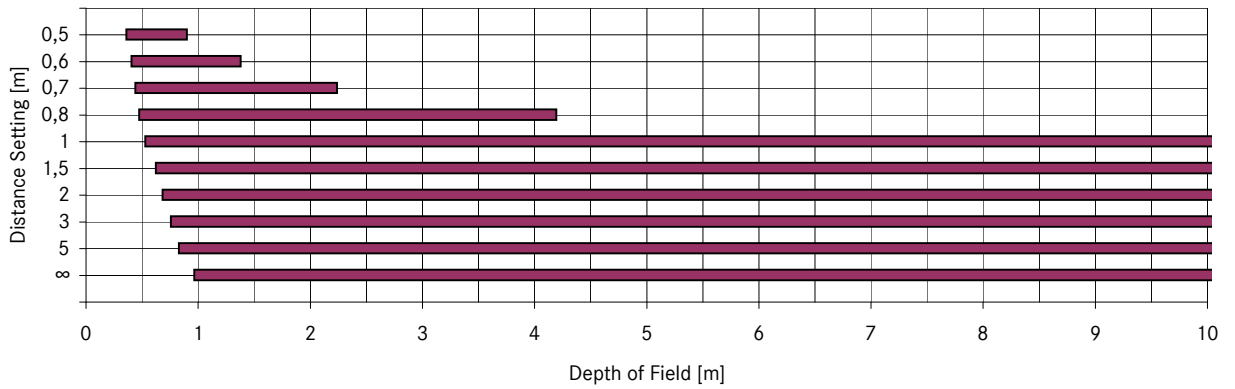

Aperture Stop 16

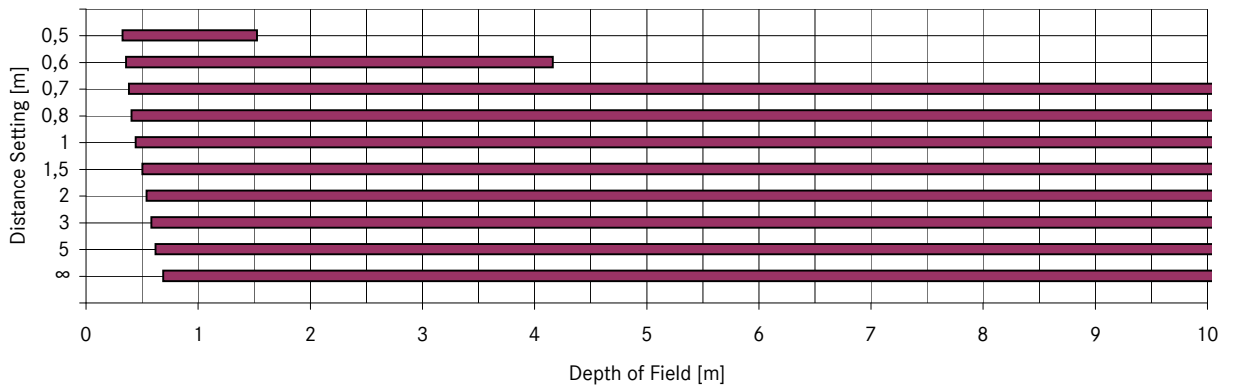

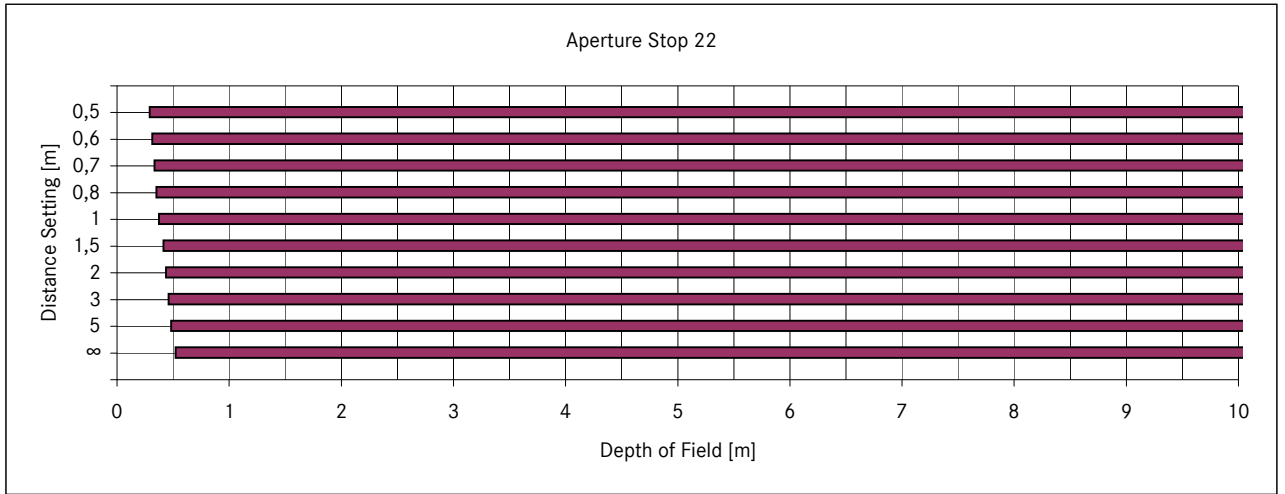



Depth of field table 21 mm

	Aperture Stop						Magnification
	4,0	5,6	8	11	16	22	
0,5	0,448 - 0,568	0,433 - 0,598	0,410 - 0,656	0,385 - 0,749	0,352 - 0,993	0,320 - 1,704	1/20,5
0,6	0,524 - 0,707	0,502 - 0,758	0,470 - 0,859	0,436 - 1,036	0,391 - 1,622	0,350 - 5,827	1/25,3
0,7	0,595 - 0,858	0,566 - 0,936	0,524 - 1,102	0,481 - 1,430	0,426 - 2,968	0,376 - ∞	1/30,2
0,8	0,663 - 1,020	0,626 - 1,137	0,574 - 1,401	0,522 - 2,000	0,455 - 7,894	0,398 - ∞	1/35,0
1	0,788 - 1,390	0,734 - 1,625	0,662 - 2,259	0,591 - 4,542	0,505 - ∞	0,433 - ∞	1/44,7
1,5	1,054 - 2,690	0,955 - 3,813	0,831 - 12,41	0,718 - ∞	0,590 - ∞	0,490 - ∞	1/68,8
2	1,268 - 5,055	1,125 - 11,69	0,953 - ∞	0,804 - ∞	0,644 - ∞	0,525 - ∞	1/93,0
3	1,590 - 42,08	1,367 - ∞	1,117 - ∞	0,914 - ∞	0,709 - ∞	0,565 - ∞	1/141
5	1,996 - ∞	1,650 - ∞	1,294 - ∞	1,026 - ∞	0,771 - ∞	0,601 - ∞	1/238
∞	3,232 - ∞	2,397 - ∞	1,699 - ∞	1,256 - ∞	0,887 - ∞	0,666 - ∞	1/∞

